

# COMPRESSION NUTS

Parts available in Nylon, Acetal Copolymer, Polypropylene, PVDF.

Sizes indicated are based on Acetal Copolymer and PVDF material shrink rates.

## Ferrule Nuts with Integral Sleeve

JACO Part No.	Matl.	Nut	Tube	O.D.	A	B	C	D
					±1/64	±1/64	THD	+005 +010
- 0 - 2	0	2	1/8		7/16	33/64	5/16-24	.125
- 0 - 4	0	4	1/4		5/8	5/8	7/16-20	.250
- 0 - 5	0	5	5/16		45/64	11/16	1/2-20	.312
- 0 - 6	0	6	3/8		13/16	47/64	5/8-20	.375
- 0 - 8	0	8	1/2		15/16	7/8	3/4-20	.500

Note: Pressure rating = 50 psi

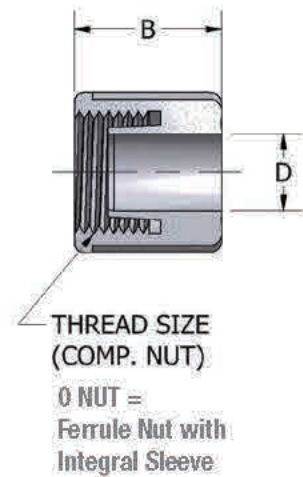

## Plastic Gripper Nuts

JACO Part No.	Matl.	Nut	Tube	O.D.	A	B	C	D
					±1/64	±1/64	THD	+005 +010
- PG - 4	PG	4	1/4		5/8	43/64	7/16-20	.250
- PG - 5	PG	5	5/16		11/16	47/64	1/2-20	.312
- PG - 6	PG	6	3/8		13/16	23/32	5/8-20	.375
- PG - 8	PG	8	1/2		15/16	7/8	3/4-20	.500
- PG - 10	PG	10	5/8		1-7/64	7/8	7/8-20	.625
- PG - 12	PG	12	3/4		1-5/16	1	1-1/16-20	.750
- PG - 14	PG	14	7/8		1-7/16	1-1/8	1-3/16-16	.875

Note: Pressure rating = 220 psi

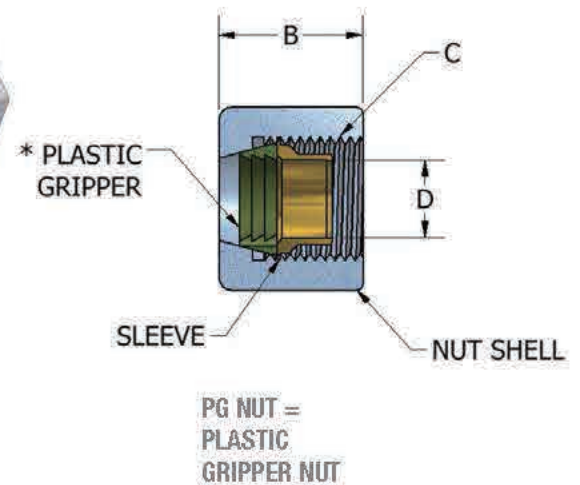

\*Note: P/K Material Nut: Use PVDF Material Gripper, N/C Material Nut: Use Acetal Copolymer Gripper

## Stainless Steel Gripper Nuts

JACO Part No.	Matl.	Nut	Tube	O.D.	A	B	C	D
					±1/64	±1/64	THD	+005 +010
- SG - 4	SG	4	1/4		5/8	43/64	7/16-20	.250
- SG - 5	SG	5	5/16		11/16	47/64	1/2-20	.312
- SG - 6	SG	6	3/8		13/16	23/32	5/8-20	.375
- SG - 8	SG	8	1/2		15/16	55/64	3/4-20	.500
- SG - 10	SG	10	5/8		1-1/8	7/8	7/8-20	.625
- SG - 12	SG	12	3/4		1-5/16	1	1-1/16-20	.750
- SG - 14	SG	14	7/8		1-7/16	1-1/8	1-3/16-16	.875

Note: Pressure rating = 220 psi

